 <b>THOMPSON RIVERS UNIVERSITY</b> Occupational Health & Safety	<b>Number:</b>	OH&S 18.42.1
	<b>Revision Date:</b>	06/30/2014
	<b>Cold Metal Cutoff Saw Safety</b>	

Printed copies of this document are uncontrolled.

**1. PURPOSE**





1.1. The purpose of these safety procedures is to provide guidelines for the safe operation of the Cold Metal Cut-Off Saw.

**2. SCOPE**





2.1. These procedures apply to all Trades Instructors, Visual Arts Instructors and all students using this machine on TRU property.

**3. PRECAUTIONS**

**POTENTIAL HEALTH & SAFETY HAZARDS**

<b>HAZARD</b>		<b>TO PROTECT YOURSELF</b>
<b>PINCH POINTS</b> There are gears and exposed moving parts on machinery.		Use <b>LOCK-OUT</b> procedures when performing maintenance or conducting any work within 12” of an exposed pinch point. <b>NEVER</b> put your hands or feet near an exposed pinch point or gears!
<b>ELECTRICAL HAZARD</b>		Ensure that all switches, wires and plugs are all in good working condition prior to using this machine.
<b>HIGH SOUND LEVELS</b> Sound levels exceed 85 dB		<b>HEARING PROTECTION</b> is required when working in designated areas.
<b>FOOT INJURY</b>		Approved protective footwear is needed when there is the risk of foot injury due to slipping, uneven terrain, abrasion, crushing potential, temperature extremes, corrosive substances, puncture hazards, electrical shock and any other recognizable hazard
<b>Rings and Dangling jewelry</b>		<b>Rings and any loose or dangling jewelry must not be worn</b> while operating any equipment or machines

#### 4. PERSONAL PROTECTIVE EQUIPMENT

	<p><b>Safety glasses must be worn at all times in work area!</b></p>
	<p><b>Long and Loose hair must be contained by a hat or hairnet to prevent contact with moving parts on equipment and machines</b></p>
	<p><b>Work Boots must be worn at all times when working in an area where there is risk of serious foot injury due materials falling onto the foot.</b></p>
	<p><b>Work Gloves should be worn when there is a risk of hand injury during the course of work tasks.</b></p>

#### 5. PROCEDURES

##### 5.1 Cold metal Cut-off Saw

Metal saws can be very dangerous if not operated properly.

- Read the owner's manual carefully prior to using machine.
- Make sure you understand instructions and are properly trained before operating a metal saw.

Cold cutting saws include hand and powered hacksaws, band saws and horizontal and vertical circular saws

Hot cutting saws use an abrasive disc or large toothless (friction) circular saw.

##### 5.2 Basic Safety Measures for Metal Saw Operation

- Wear appropriate safety glasses.
- Ensure the saw has a start/stop button within easy reach of the operator.
- Ensure that all guards are in place and working properly.

- Guard long material at both ends to prevent anyone from coming into contact with it.
- Ensure that the blade is completely stopped before removing the stock.
- Use cutting or lubricating fluid when cutting metals.
- Keep saw blade clean and sharp. Check blades regularly for wear or damage.

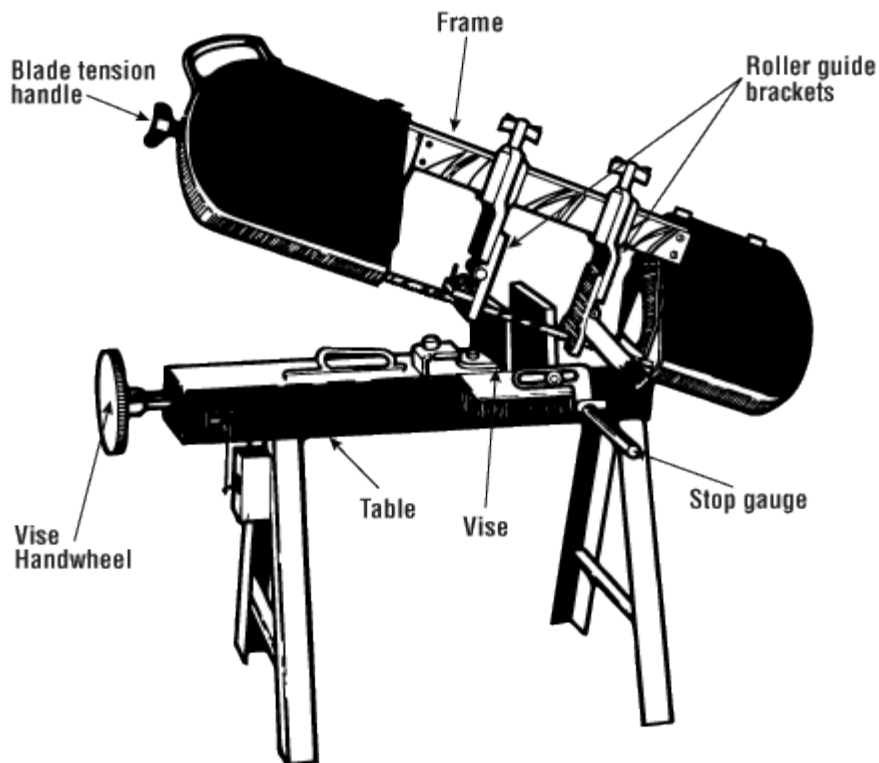

- Select the correct blade and saw speed for the material being cut.
- Use the stop gauge supplied with most cut-off saws when several pieces of the same length are required.
- Secure all work in a vise. Place the section to be cut such that the saw blade will clear the vise and table; however, do not place the section so far away from the vise that it will be unstable when being cut.
- Support long stock with a floor stand.
- Safe guards must be provided to prevent a worker from contacting stock projecting from the machine.

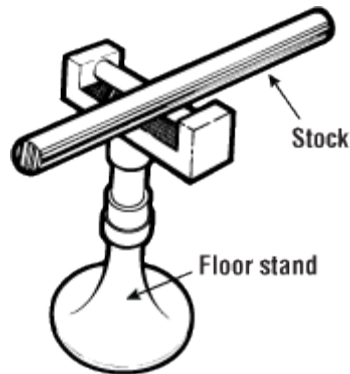

- Keep working area clean of scraps, tools and materials.
- Keep floor around the Metal Saw free of oil, grease and debris.
- Cuttings or cooling fluids, metal chips, or turnings from machine tool work must be contained.

**5.3 Beware of the following hazards while operating a Metal Cut-off Saw**

- Do not place, measure or remove work unless the saw has come to a complete stop.
- Do not apply extra force to the saw blade; this could result in the blade breaking and possible injuries from flying parts.
- Do not leave Metal Cut-off Saws unattended while in operation.

**6. RECORDS/VERIFICATION OF UNDERSTANDING**

6.1. Records

6.1.1 – Records of students training on the Metal Saw will be kept with the Instructor and the Chairperson of that Department.

6.2. Verification of Understanding

7. A training master log will be maintained by The Department Chairperson and the Dean of Trades.

**8. SUMMARY OF CHANGES**

Revision #	Date	Change (include section #)	Issued By
1	06/30/2014	NEW	OHS Officer